

# 319D / 323D

Engine	319D	323D
Manufacturer and Model	John Deere PowerTech™ E 4024HT	John Deere PowerTech E 4024HT
Non-Road Emissions Standard	EPA Interim Tier 4/EU Stage IIIB	EPA Interim Tier 4/EU Stage IIIB
Cylinders	4	4
Net Peak Power (SAE J1349 / ISO 9249)	47.1 kW (63 hp) at 2,300 rpm	51.4 kW (69 hp) at 2,300 rpm
Gross Peak Power (ISO 14396)	50.8 kW (68 hp) at 2,300 rpm	55.0 kW (74 hp) at 2,200 rpm
Peak Torque	230 Nm (170 ft.-lb.) at 2,000 rpm	260 Nm (192 ft.-lb.) at 2,000 rpm
Displacement	2.4 L (149 cu. in.)	2.4 L (149 cu. in.)
Net Torque Rise	27% at 1,600 rpm	38% at 1,800 rpm
Aspiration	Turbocharged and intercooled	Turbocharged and intercooled
Air Cleaner	Dry dual element	Dry dual element
Cooling	319D / 323D	
Fan Drive	Variable-speed hydraulic drive	
Powertrain	319D	323D
Pump	Axial-piston hydrostatic	Axial-piston hydrostatic
Travel Speeds		
Single Speed	9.8 km/h (6.1 mph)	9.8 km/h (6.1 mph)
2 Speed, Optional		
Low	—	8.9 km/h (5.5 mph)
High	—	13.7 km/h (8.5 mph)
Brake	Integral, automatic, spring applied, hydraulically released wet-disc brake	
Undercarriage	New-generation smooth-ride long-life rubber with steel inserts	
Rubber Tracks	New-generation smooth-ride long-life rubber with steel inserts	
Track Width		
Standard	320 mm (12.6 in.)	320 mm (12.6 in.)
Optional	—	400 mm (15.8 in.)
Ground Pressure		
Standard 320-mm (12.6 in.) Track	37.2 kPa (5.4 psi)	37.2 kPa (5.4 psi)
Optional 400-mm (15.8 in.) Track	—	30.6 kPa (4.4 psi)
Track Rollers (per side)	4 triple-flange smooth-ride all-steel rollers	4 triple-flange smooth-ride all-steel rollers
Track Idlers (per side)	2 double-flange smooth-ride all-steel rollers	2 double-flange smooth-ride all-steel rollers
Bearings/Seals (rollers/idlers)	Heavy-duty journal bearings and metal face seals	Heavy-duty journal bearings and metal face seals
Tractive Effort	3629 kgf (8,000 lbf)	3629 kgf (8,000 lbf)
Hydraulics		
Pump Flow		
Standard	59 L/m (15.5 gpm)	72 L/m (19 gpm)
High-Flow Option Total	—	110 L/m (29 gpm)
System Pressure at Couplers	21 374 kPa (3,100 psi)	23 787 kPa (3,450 psi)
Hydraulic Horsepower (calculated)		
Standard Flow	22.4 kW (30 hp)	29.8 kW (40 hp)
High-Flow Option	—	46.2 kW (62 hp)
Cylinders	319D / 323D	
John Deere heat-treated, chrome-plated, polished cylinder rods, hardened steel (replaceable bushings) pivot pins		
Electrical		
Voltage	12 volt	
Battery Capacity	750 CCA (optional 925 CCA)	
Alternator Rating	70 amp	
Lights	Halogen, 2 front and 1 rear standard	
Operator's Station		
ROPS (ISO 3471)/FOPS (ISO 3449) structure with quick-pivot standard		
Serviceability		
Refill Capacities		
Fuel Tank	70.0 L (19.0 gal.)	

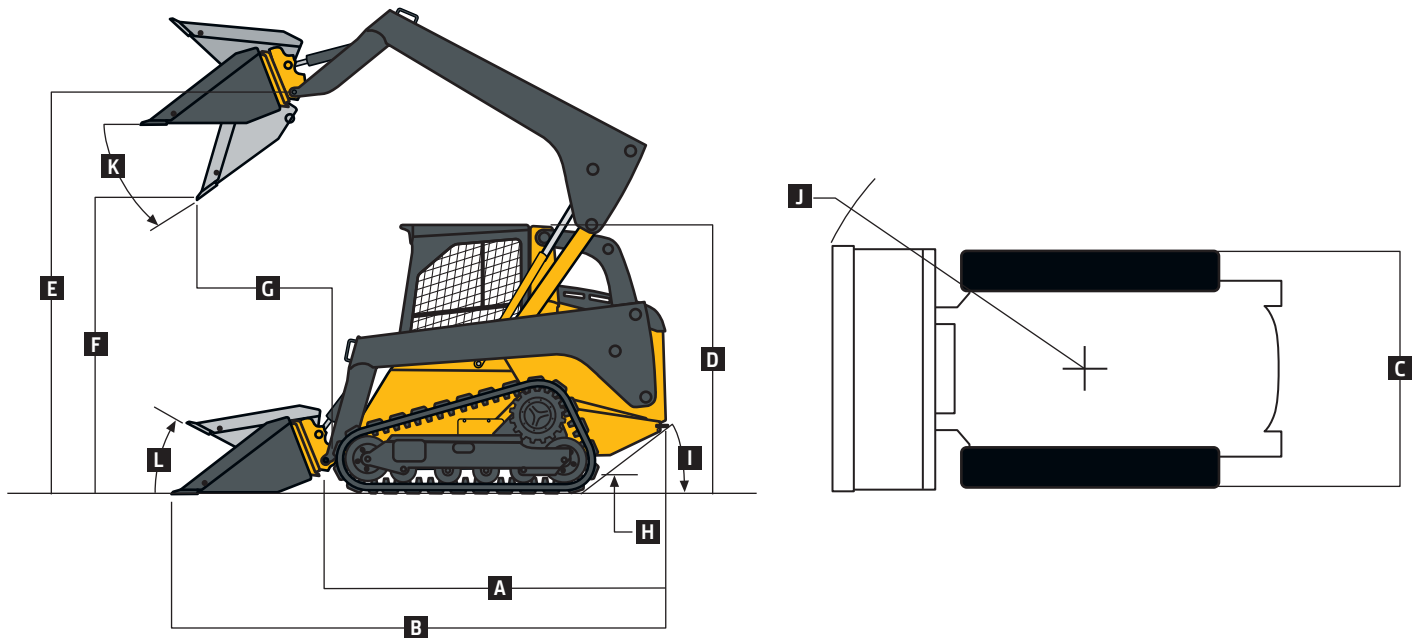

Operating Weights	319D	323D
Track		
320-mm (12.6 in.) Standard	3882 kg (8,550 lb.)	3882 kg (8,550 lb.)
400-mm (15.8 in.) Optional	—	3984 kg (8,775 lb.)
Machine Dimensions		
<b>A</b> Length without Bucket	2.74 m (9 ft. 0 in.)	2.74 m (9 ft. 0 in.)
<b>B</b> Length	3.36 m (11 ft. 0 in.)	3.36 m (11 ft. 0 in.)
<b>C</b> Width without Bucket		
With 320-mm (12.6 in.) Track	1.82 m (6 ft. 0 in.)	1.82 m (6 ft. 0 in.)
With 400-mm (15.7 in.) Track	—	1.91 m (6 ft. 3 in.)
<b>D</b> Height to Top of ROPS	2.00 m (6 ft. 7 in.)	2.00 m (6 ft. 7 in.)
<b>E</b> Height to Hinge Pin	3.00 m (9 ft. 10 in.)	3.00 m (9 ft. 10 in.)
<b>F</b> Dump Height	2.40 m (7 ft. 11 in.)	2.40 m (7 ft. 11 in.)
<b>G</b> Dump Reach		
With Foundry Bucket	721 mm (28.4 in.)	721 mm (28.4 in.)
With Construction Bucket	0.92 m (3 ft. 0 in.)	0.92 m (3 ft. 0 in.)
<b>H</b> Ground Clearance	250 mm (9.8 in.)	250 mm (9.8 in.)
<b>I</b> Angle of Departure	25 deg.	25 deg.
<b>J</b> Front Turn Radius	2.01 m (6 ft. 7 in.)	2.01 m (6 ft. 7 in.)
<b>K</b> Dump Angle (full lift height)	42 deg.	42 deg.
<b>L</b> Bucket Rollback (ground level)	32 deg.	32 deg.



Loader Performance	319D	323D
Tipping Load	2542 kg (5,600 lb.)	3257 kg (7,175 lb.)
SAE Rated Operating Capacity with Foundry Bucket		
At 35% Tipping Load	863 kg (1,900 lb.)	1042 kg (2,295 lb.)
At 50% Tipping Load	1271 kg (2,800 lb.)	1634 kg (3,600 lb.)
Boom Breakout	1589 kg (3,500 lb.)	1680 kg (3,700 lb.)
Bucket Breakout Force	2327 kg (5,125 lb.)	2542 kg (5,600 lb.)