

# Specifications

MODEL		GTH™-5519	
MEASUREMENTS	US	Metric	
Maximum lift height	18 ft 10 in	5.74 m	
Reach	11 ft 3 in	3.43 m	
Reach at maximum height	1 ft 10 in	0.56 m	
<b>A</b> Height, stowed	6 ft 6 in	1.98 m	
<b>B</b> Length, stowed (without forks)	12 ft 3 in	3.73 m	
Width	5 ft 11 in	1.80 m	
<b>C</b> Wheelbase	7 ft 6 in	2.29 m	
<b>D</b> Ground clearance, center	1 ft 2 in	0.36 m	
<b>E</b> Ground clearance, axle	10 in	0.25 m	
Fork cross section	1.6 x 4 in	40 x 100 mm	

PRODUCTIVITY		
Maximum lift capacity	5,500 lbs	2,500 kg
Lift capacity at maximum height	4,400 lbs	1,996 kg
Lift capacity at maximum reach	1,700 lbs	771 kg
Drive speed	15 mph	24.1 km/h
Draw bar pull	10,250 lbs	4,649 kg
Turning radius, inside (4WS)	5 ft 6 in	1.68 m
Turning radius, outside (4WS)	11 ft	3.35 m
Auxiliary hydraulic flow	17 gpm	64 lpm
Auxiliary hydraulic pressure	3,918 psi	270 bar
Tires, standard size	12 x 16.5 in, 10 ply	

POWER		
Power source	Deutz F4M2011 4 cylinder diesel 63 hp (47.0 kW)	
Hydraulic tank capacity	18.5 gal	70 L
Hydraulic system capacity (w/tank)	31.7 gal	120 L
Fuel tank capacity	15.8 gal	59.8 L

WEIGHT		
Weight*	10,000 lbs	4,536 kg

STANDARDS COMPLIANCE	ASME B 56.6, ISO 3471, ISO 3449
----------------------	---------------------------------

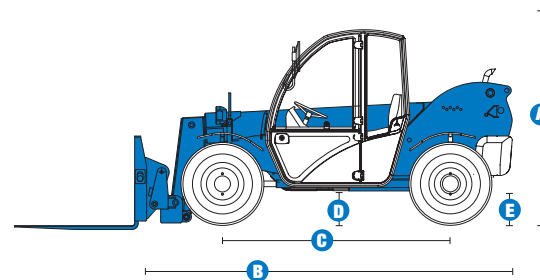

## LOAD CHART GTH™-5519\*\*

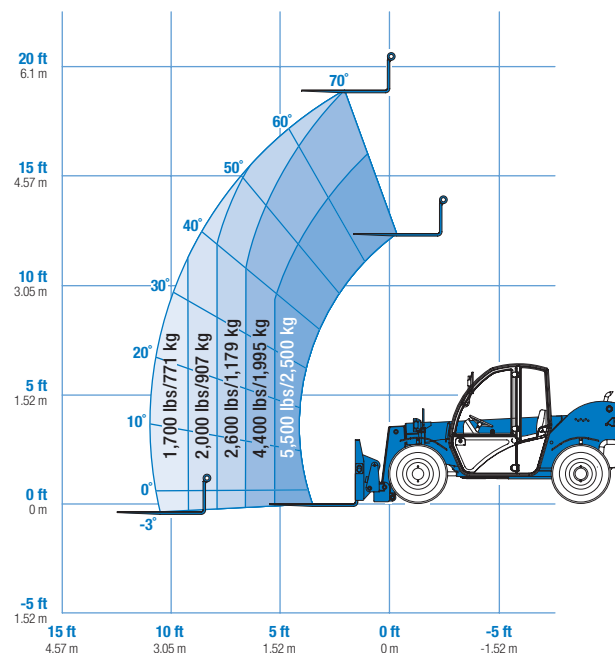

\* Weight will vary depending on options and/or country standards.  
 \*\* Load ratings vary depending on attachment.